

DP 1269

FIFTH FIVE HOLE BATH SET WITH WALL MOUNTED
SPOUT, DIVERTER & PULLOUT HAND SHOWER

INSTALLATION GUIDE

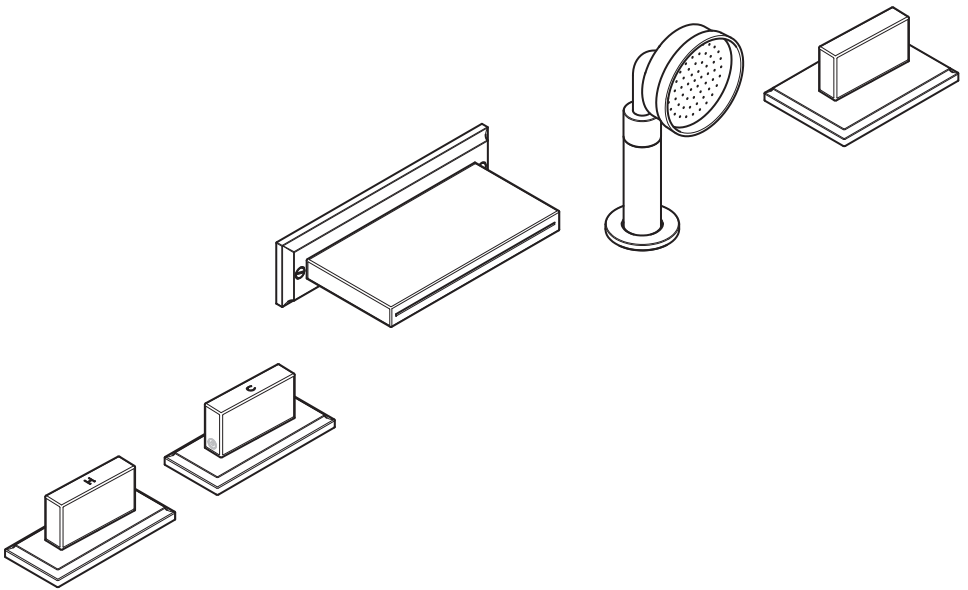

LEFROY BROOKS

DIMENSIONS

Flow valves

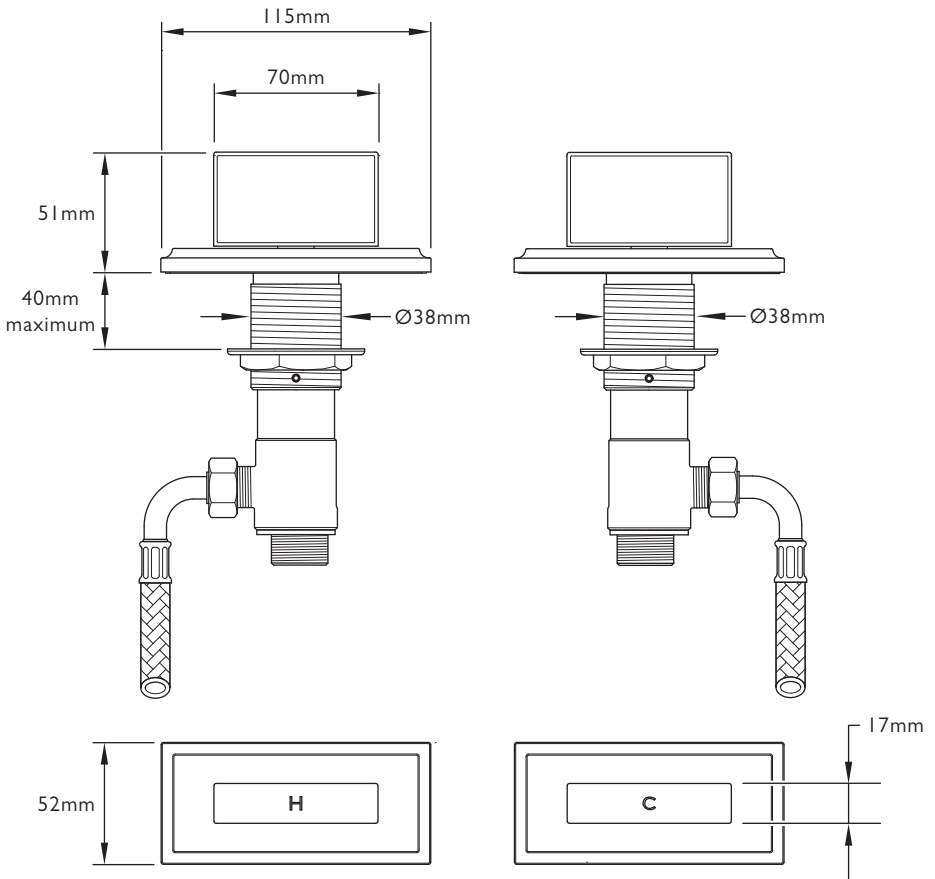

Not to scale

DIMENSIONS

Spout

Note: The fittings and pipework between the spout and diverter valve are the responsibility of the plumber.
Lefroy Brooks do not supply the fittings or pipes for this connection.

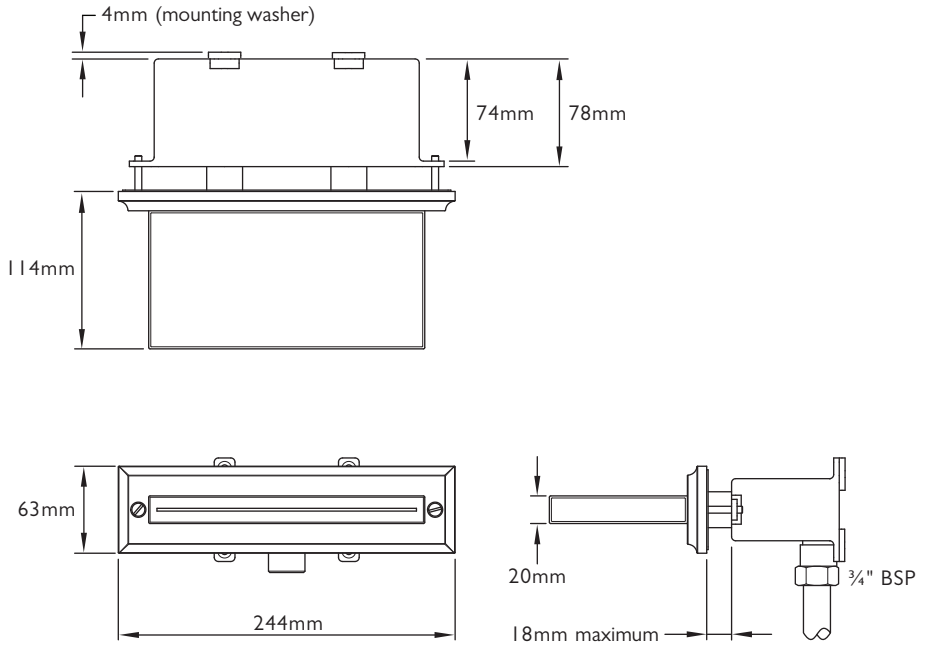

Not to scale

DIMENSIONS

Diverter and hand shower

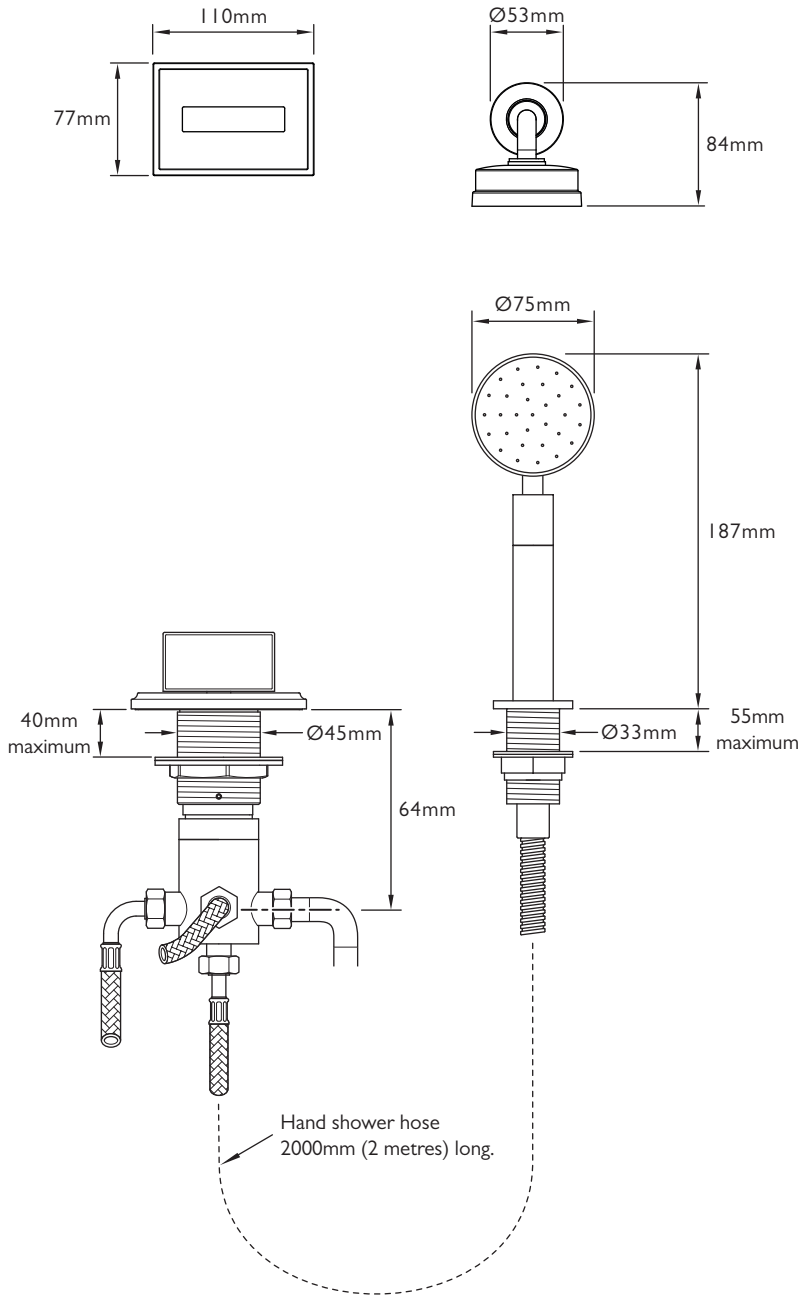

Not to scale

DIVERTER VALVE CONNECTIONS

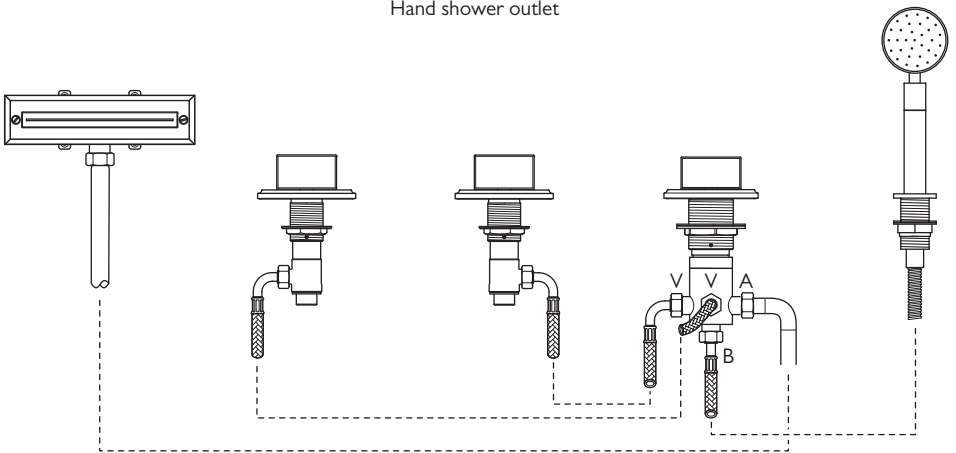
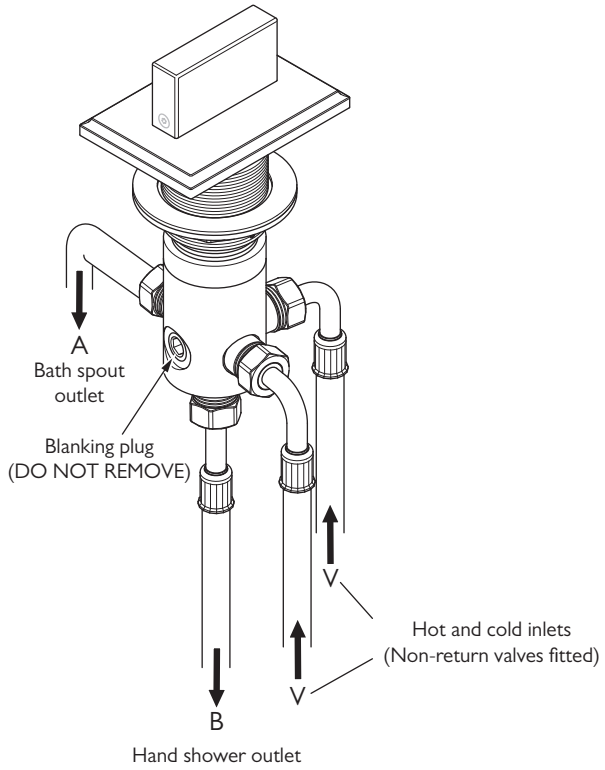

MOUNTING DISTANCES

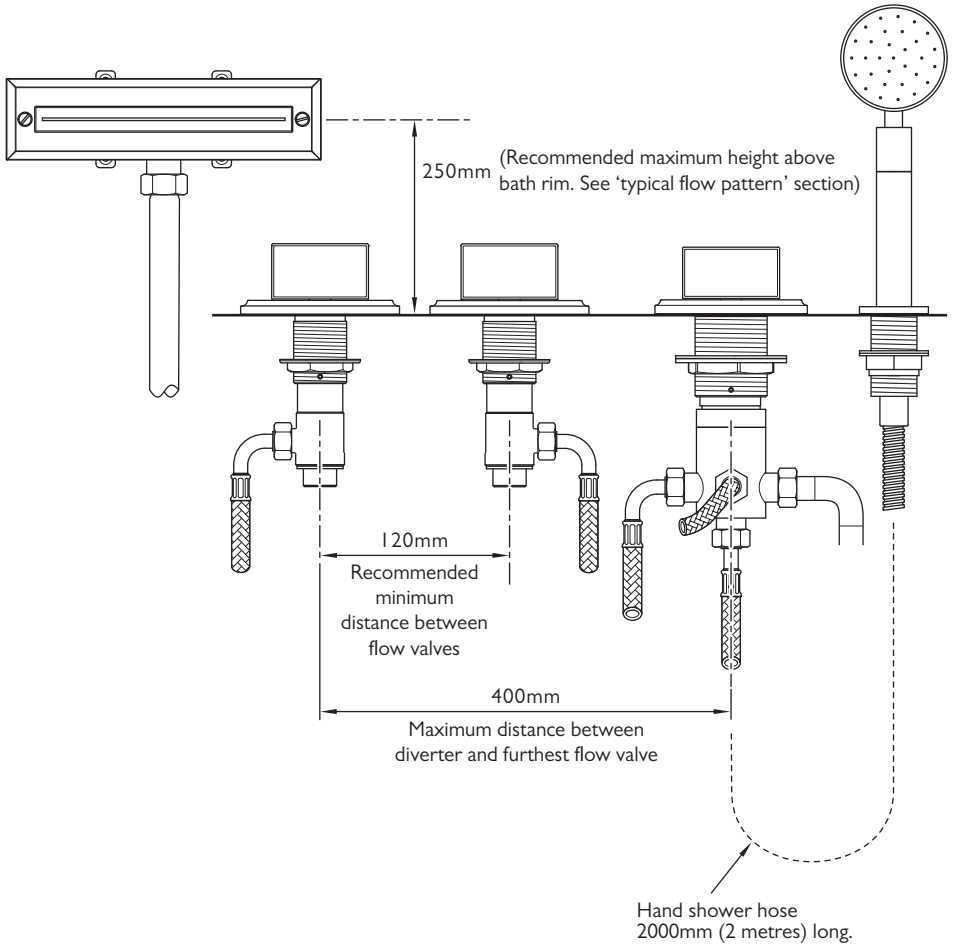

Not to scale

IMPORTANT INFORMATION

Professional installation

We recommend that our products are fitted by a fully qualified professional plumber. They should be installed correctly and in accordance with all local water regulations and the system protected by non-return valves (not supplied). All products should be accessible for routine servicing.

Suits all systems

This Lefroy Brooks product is potentially suitable for every possible application, type of boiler and water supply pressure. However, if your supply pressure is below 1 bar it is advisable to fit a water pump. For systems with combination boilers, it is not advisable to fit pumps (refer to boiler manufacturer).

Supply temperature safety notice

To comply with local building regulations, current legislation, relevant standards and codes of practice a thermostatic mixing valve (TMV) should be fitted (not supplied) to the hot supply. This will restrict the temperature to a safe working maximum temperature. Maximum allowed temperatures vary subject to type of installation or specification of building.

Balancing flow

If there is a significant difference in water pressures between hot & cold supplies, we recommend an in-line flow suppressor/regulator (not supplied) be fitted. This should be fitted to whichever has the greater flow rate, in an accessible position close to the valve.

Flushing system

It is most important to flush out all pipework thoroughly before connecting the product. Failure to do so is the single most common cause of ceramic cartridge failure.

Servicing

All serviceable parts are available to maintain your Lefroy Brooks product.

Water quality

In hard water areas, a suitable water treatment system should be provided to prevent limescale deposits (calcium deposits) which may effect the long term performance of the ceramic cartridges. Exterior surfaces should be gently wiped with a dry soft cloth after use to minimise water stains and limescale deposits.

Diverter valve

The diverter valve should be connected to the hot and cold supplies using ½" BSP braided hoses. Note: if using a mixed supply, one inlet can be blanked off using a ½" BSP blanking cap (not supplied).

Inlets and outlets

Side inlets 'V' – hot & cold inlets
Side outlet 'A' – bath spout/filler
Bottom outlet 'B' – hand shower hose

Note: The hot and cold supplies should be protected by non-return valves (supplied) to avoid any damage that could be caused by cross-flow.

Restrictions for use

The diverter valve will only divert the water supply from one application to another.

It will not:

- Control temperature
- Control water flow rate
- Isolate water supply
- Operate two applications simultaneously

Spout

- Do not use the spout for support when entering/leaving the bath.
- Do not hang items from the spout.
- Do not use the top of the spout for storage or place items on top including candles, soaps, cosmetics etc.

TYPICAL FLOW RATES

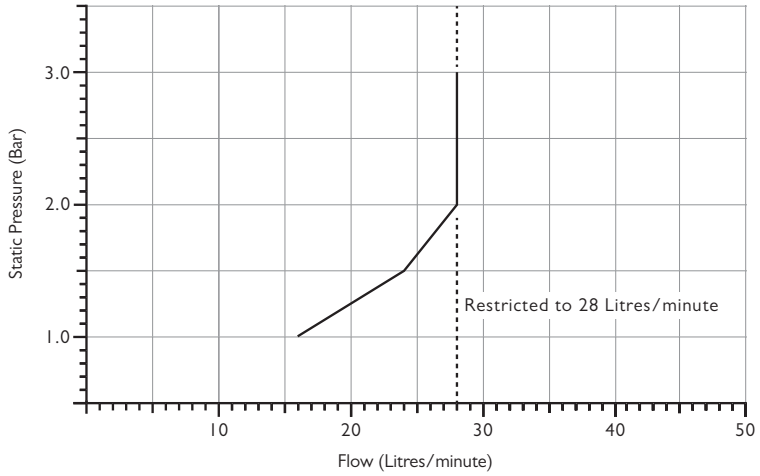

Note: Balanced pressures shown are applied directly to the hot and cold inlets; flow rates indicated are free flowing and may vary subject to restrictions created by installation, pipework, layout or application.

TYPICAL FLOW PATTERN

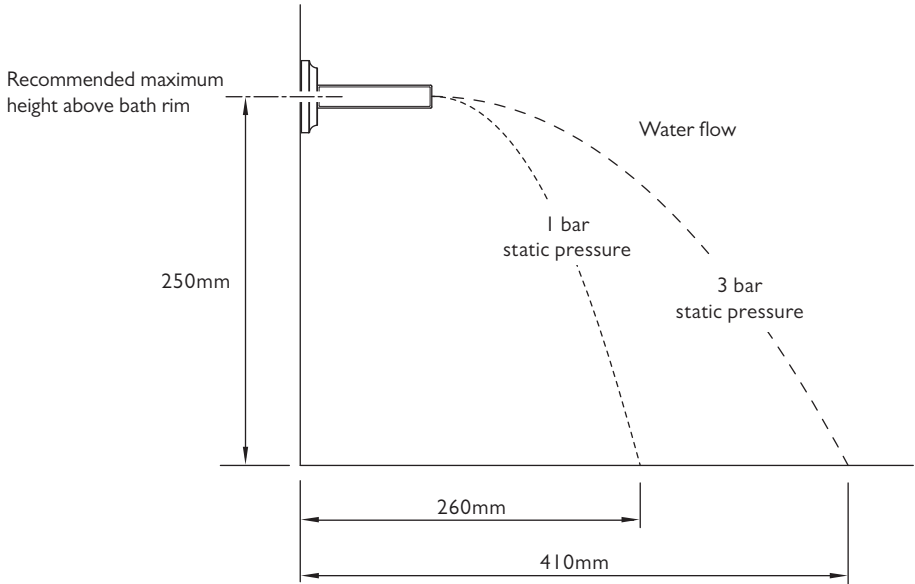

Not to scale

The flow rate for the spout has been restricted to 28 litres per minute. This is to limit the distance that water will travel when leaving the spout. If the spout is mounted to the side of a bath the water pressure may require adjustment to ensure water does not flow over the side of the bath and onto the floor. The illustration shows the distance water is projected from the spout at 1 bar and 3 bar static pressure.

INSTALLATION

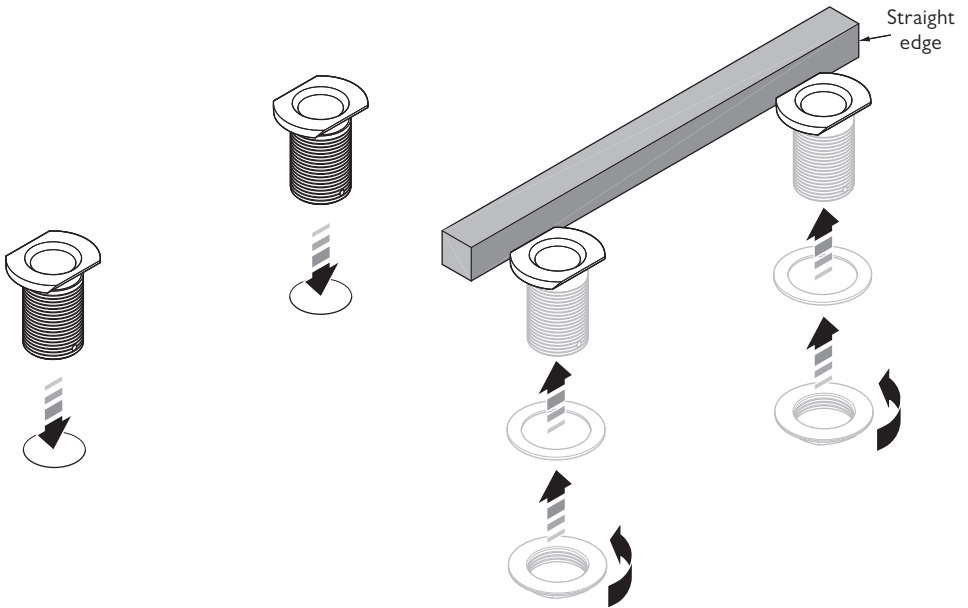

- 1 Cut suitable holes in the work surface.
- 2 Locate the flow valve supports into the holes.
- 3 Place a straight edge against the rear of the flow valve supports to ensure they are aligned correctly.

- 4 With the washers in place, screw the flow valve support backnuts in place to secure. Ensure that the supports remain aligned.

INSTALLATION

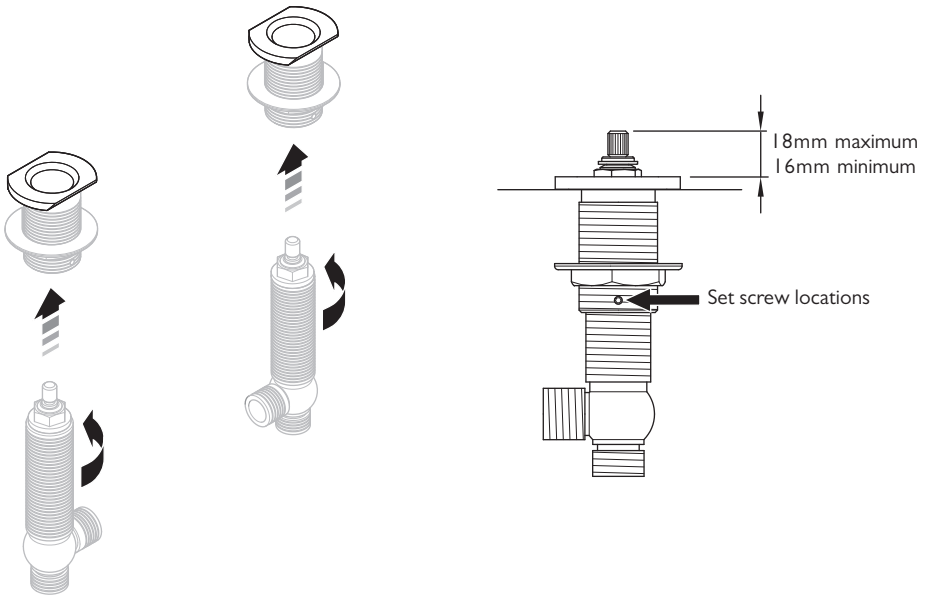

- 5 Screw the flow valves into the flow valve supports.
- 6 Set the height of the flow valves as shown above. The upper surface of the splined tips should be between 16mm and 18mm above the top of the flow valve supports.
- 7 To align the handles locate a handle onto the left hand flow valve and rotate fully clockwise. Locate a handle onto the right hand flow valve and rotate fully counter clockwise. Where necessary, rotate the flow valve body to ensure that the front face of each handle is parallel to the front face of the flow valve supports.
- 8 Each flow valve support has two set screws located in it. Using a 2mm hexagonal key secure the flow valves by screwing in the set screws.
- 9 Remove the handles.

INSTALLATION

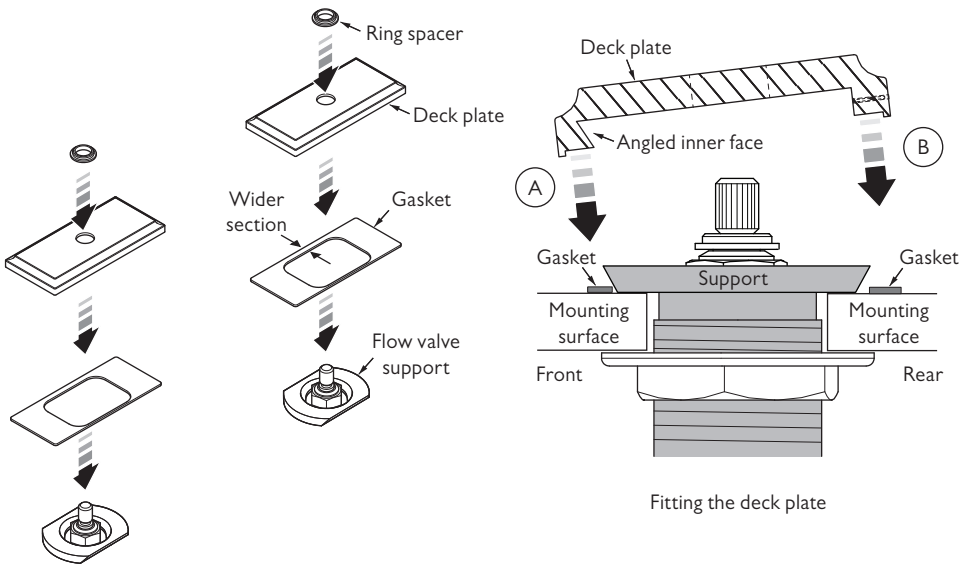

- 10 Place the gaskets over the flow valves. The holes in the gaskets are not central. Ensure that the wider sections are located to the rear of the flow valve supports.
- 11 The flow valve deck plates have a front and rear, the rear having a small set screw hole. The front of the deck plate has an angled inner face as shown above. Locate the front of the deck plates over the flow valve supports (A) then lower the rear of the deck plates onto the gaskets (B). Screw in the two set screws at the rear of the deck plates using a 1.5mm hexagonal key to secure.
- 12 Place the ring spacers over the cartridge holes in the deck plate (The wider diameter should be at the bottom).

INSTALLATION

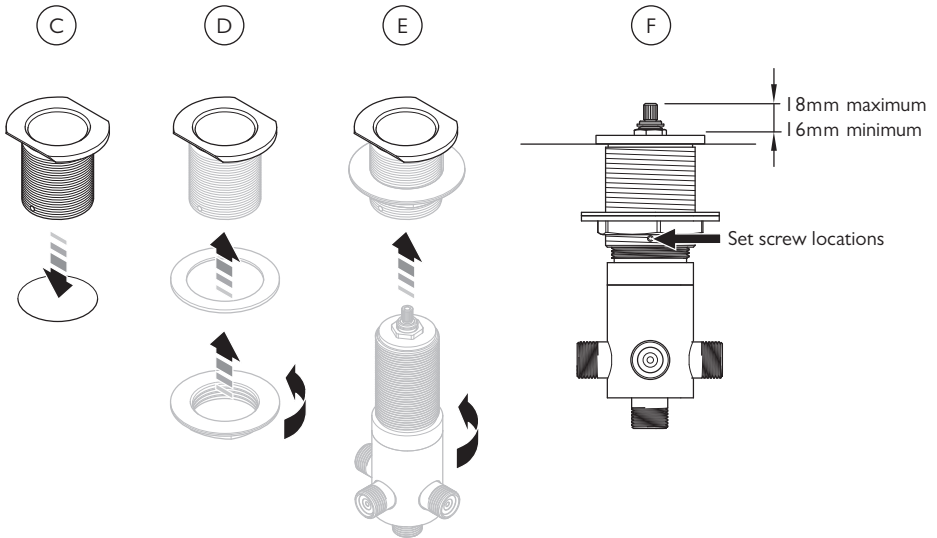

- 13 Cut a suitable hole in the work surface for the diverter valve.
- 14 Locate the diverter valve support into the hole (C).
- 15 With the washer in place, screw the diverter valve support backnut in place to secure (D).
- 16 Screw the diverter valve into the support (E).
- 17 Set the height of the flow valves as shown above. The upper surface of the splined tips should be between 16mm and 18mm above the top of the diverter valve support (F).
- 18 To align the handles locate a handle onto the diverter valve and rotate fully clockwise. Where necessary, rotate the diverter valve body to ensure that the front face of the handle is parallel to the front face of the diverter valve support.
- 19 The diverter valve support has two set screws located in it. Using a 2mm hexagonal key secure the diverter valve by screwing in the set screws.
- 20 Remove the handle.

INSTALLATION

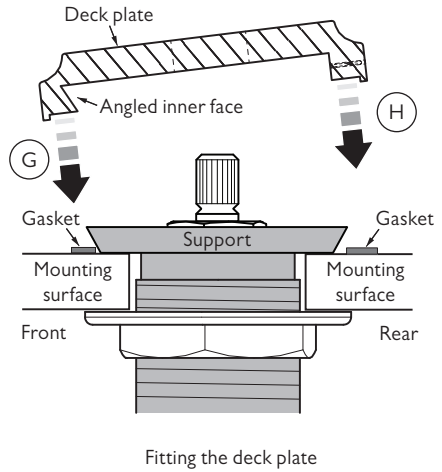
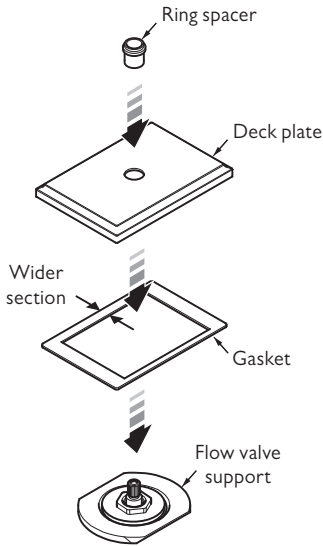

- 21 Place the gasket over the diverter. The hole in the gasket is not central. Ensure that the wider section is located to the rear of the diverter support.
- 22 The diverter deck plate has a front and rear, the rear having a small set screw hole. The front of the deck plate has an angled inner face as shown above. Locate the front of the deck plate over the diverter support (G) then lower the rear of the deck plate onto the gasket (H). Screw in the set screw at the rear of the deck plate using a 1.5mm hexagonal key to secure.
- 23 Place the ring spacer over the cartridge hole in the deck plate.

INSTALLATION

Removing the set screw covers

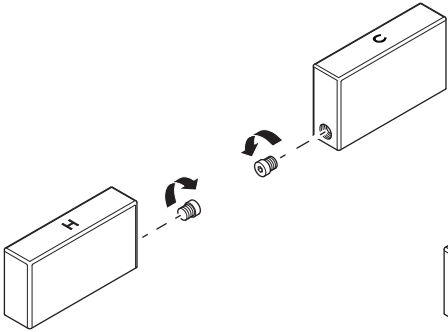

Tightening the set screws

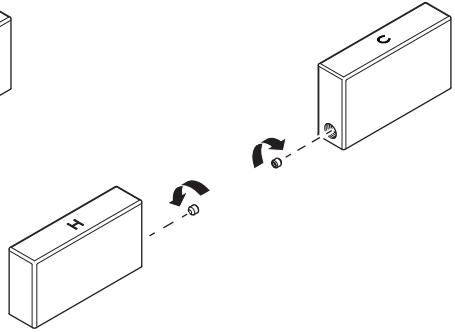

- 24 Each handle has a removable circular cover located to one side. These each cover a set screw. Unscrew and remove both covers using a 2.5mm hexagonal key.
- 25 Locate the handles onto the flow valves ensuring that the front face of each handle is parallel to the deck plate; if not aligned then see 7. Secure the handles in place using a 2mm hexagonal key.

- 26 Locate the removable covers and secure in place.
- 27 Repeat this process for the diverter handle. Always locate the removable circular cover to the less visible side wherever possible.

INSTALLATION

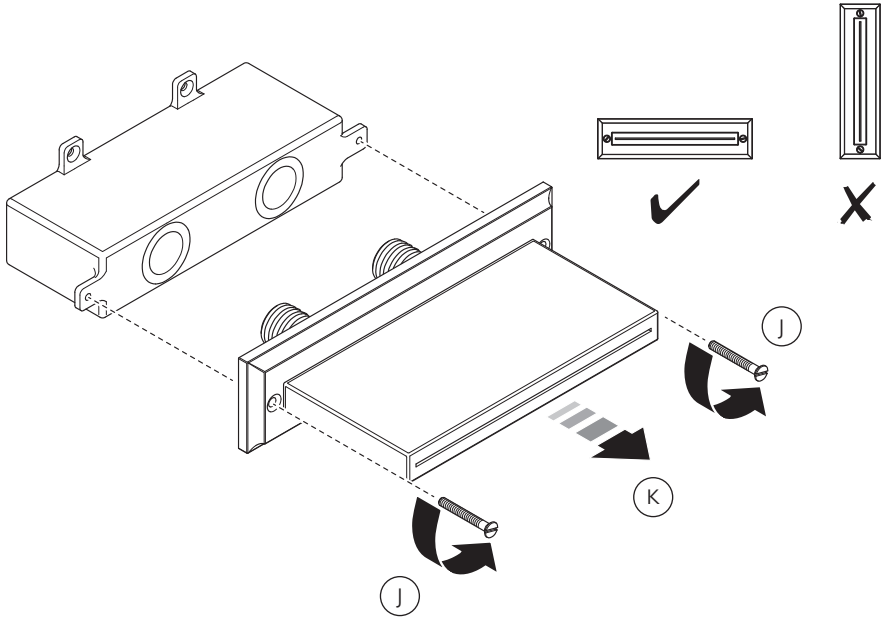

28 The spout is supplied assembled. Unscrew and remove the two retaining screws from the sides of the spout (J) then pull the spout away from the inlet chamber (K).

29 The spout is designed to be mounted horizontally, not vertically. The inlet chamber can be mounted with the inlet at the top or bottom.

INSTALLATION

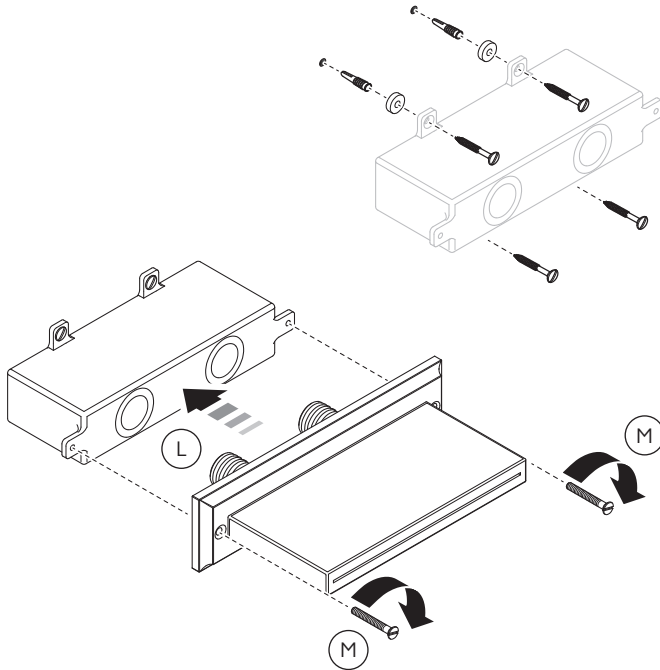

- 30 There are four mounting points on the inlet chamber. Use all four when securing the inlet chamber to the mounting surface. Mark the hole positions on the mounting surface. Use a spirit level to ensure the holes are level.
- 31 Drill holes using a $\text{\O}6\text{mm}$ drill bit.
- 32 Insert the wall plugs into the holes then secure the inlet chamber using the screws and mounting washers supplied. Use a spirit level to ensure the inlet chamber is level.
- 33 Insert the two spout connectors into the inlet chamber holes (L). Ensure the spout is kept parallel to the inlet chamber when pushing the spout connectors into the holes.
- 34 Secure the spout in place with the two screws previously removed (M).

INSTALLATION

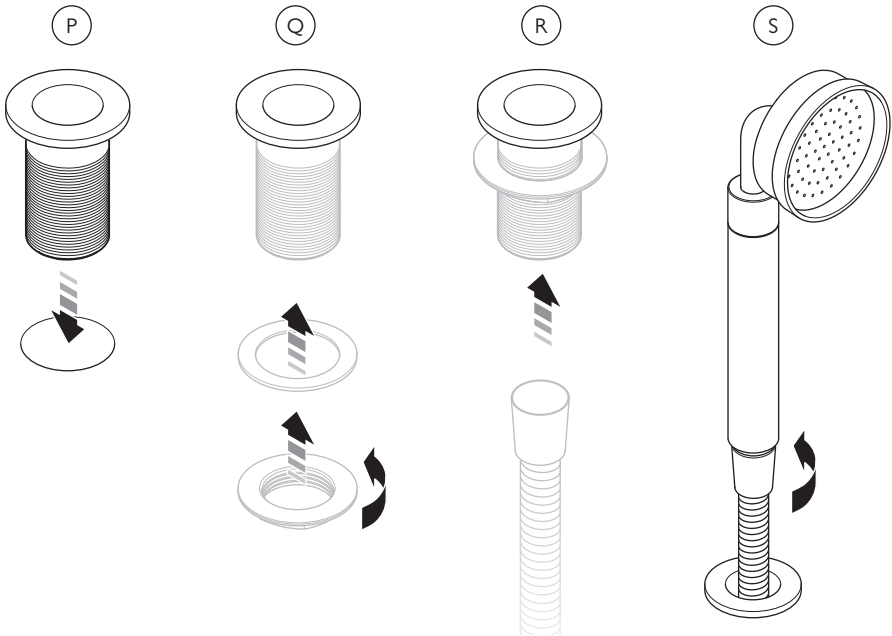

- 35 Cut a suitable hole in the work surface for the hand shower support.
- 36 Locate the hand shower support into the hole (P).
- 37 With the washer in place, screw the hand shower support backnut in place to secure (Q).
- 38 Pass the shower hose through the support (R).
- 39 Screw the shower hose onto the bottom of the hand shower then rest the hand shower in the support (S).
- 40 Connect the shower hose to the bottom of the diverter.
- 41 Connect the flexible hoses to the diverter, spout and flow valves as shown in the 'Dimensions' section. It is important to avoid tight bends which may flatten the hoses causing reduced water flow.
- 42 Connect the shower hose to the bottom of the diverter.
- 43 Connect the hot and cold water supplies to the bottom of the appropriate flow valves. Turn on the water supplies and check for leaks. Check the operation of the diverter and flow valves.

SERVICING THE DIVERTER VALVE

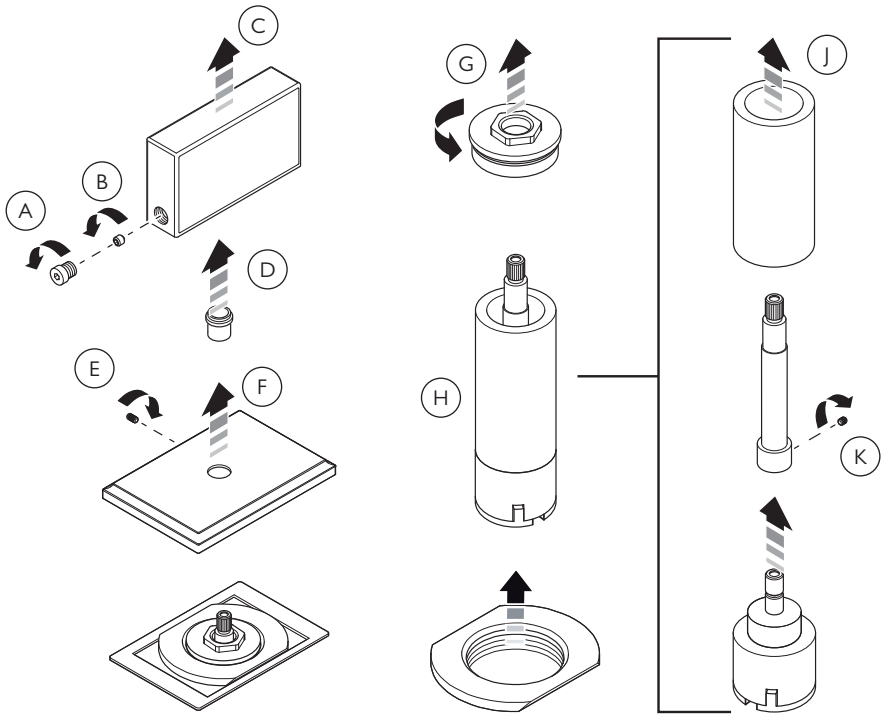

Before continuing please ensure that the water supplies have been isolated and drained where necessary.

- 1 Using a 2.5mm hexagonal key unscrew and remove the circular cover from the side of the diverter lever (A).
- 2 Using a 2.0mm hexagonal key unscrew the set screw from the side of the diverter lever (B).
- 3 Pull the handle to remove (C).
- 4 Remove the plastic spacer from the top of the deck plate (D).
- 5 Using a 1.5mm hexagonal key unscrew the set screw from the rear of the deck plate (E).
- 6 Lift the deck plate away from the diverter (F). Be careful not to damage the gasket when doing so.
- 7 Support the bottom of the diverter then unscrew and remove the top cover from the diverter (G). This will expose the diverter sleeve and cartridge assembly.
- 8 Remove the 'diverter sleeve and cartridge assembly' from the diverter body. To do this grip the spline at the top then pull upward (H).
- 9 Pull the sleeve from the 'diverter sleeve and cartridge assembly' (J).
- 10 Using a 2.0mm hexagonal key release the cartridge by unscrewing the set screw from the side of the diverter cartridge extension (K).
- 11 Replace the diverter cartridge. There are two location pegs on the underside of the cartridge. When fitting the cartridge ensure that the pegs locate into the holes in the diverter base.
- 12 Assemble in reverse order.

SERVICING THE SPOUT

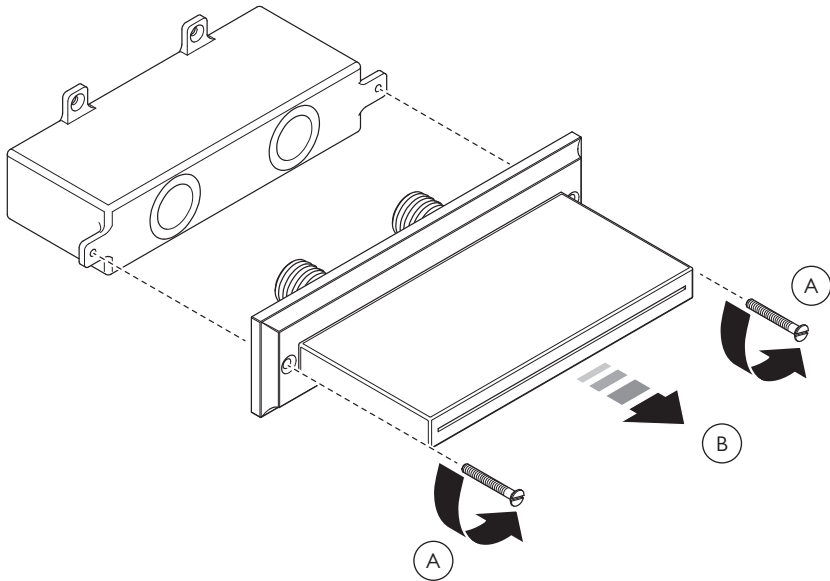

Before continuing please ensure that the water supplies have been isolated and drained where necessary.

- I To remove the spout, unscrew and remove the two retaining screws from the sides of the spout (A) then pull the spout away from the inlet chamber (B).

SERVICING THE SPOUT

Underside of spout shown.

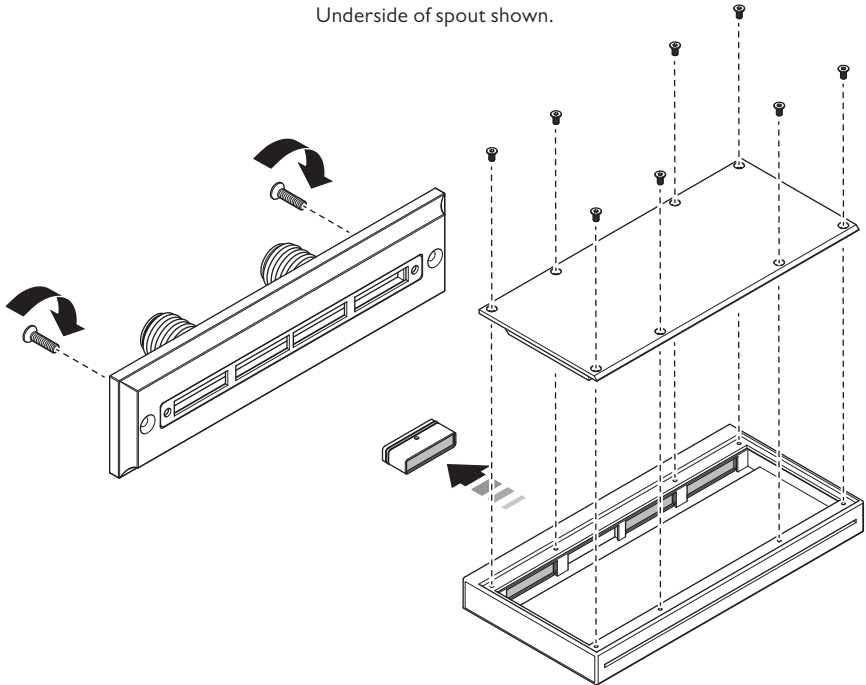

- 2 To separate the two halves of the spout assembly unscrew and remove the two screws from the rear of the spout.
- 3 To access the inside of the spout unscrew and remove the eight retaining screws from the lower access plate.
- 4 For cleaning purposes the aerators can be pushed out by applying light pressure from inside the spout. The aerators straighten the flow of water and assist in the prevention of drips when the spout is turned off. Never use the spout without the aerators in place.

SERVICING THE SPOUT

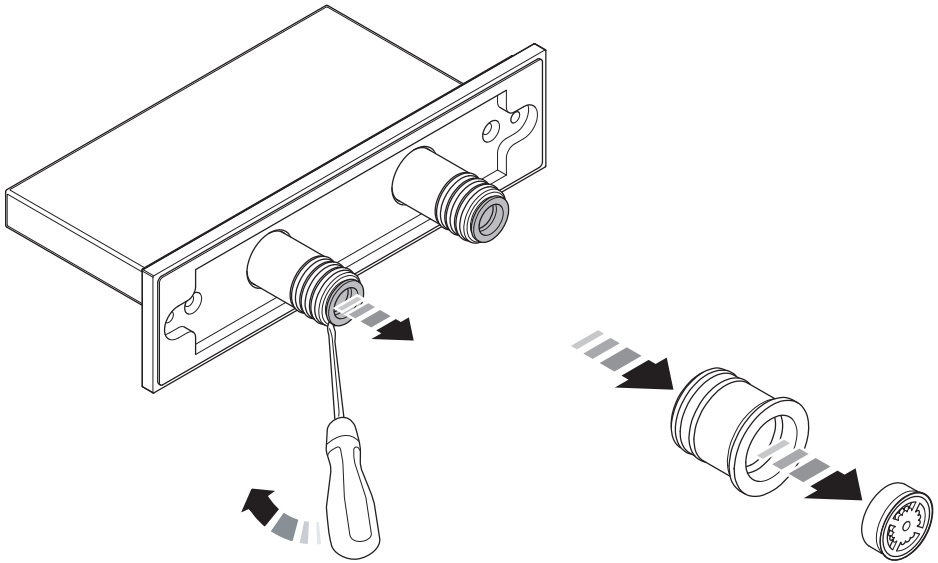

- 5 There are flow regulators located in the rear of the spout connectors. For cleaning purposes, insert a flat blade screwdriver behind the raised lip of the regulator housings to remove. The regulators can be pushed from the housings using a finger, never use anything sharp as this may damage the regulator. Simply push from inside the housing as shown above. Never use the spout without the flow regulators in place. Changes in water supply pressure could dramatically change the distance that water is projected from the spout.

FAULT FINDING

The hot/cold taps are turned off but the spout drips continuously.

- Replace the ceramic cartridge(s). See below for replacement part numbers.

The diverter fails to divert water to and from the spout and hand shower, or water flows from both the spout and hand shower at the same time.

- Replace the two way diverter cartridge. See below for replacement part numbers.

Water flow from the spout is reduced.

- Debris from the water supply may be causing restriction at the flow regulators or aerators. The flow regulators and aerators can be removed for cleaning. See 'servicing the spout' section.

REPLACEMENT PARTS

PHL036 – Pair of $\frac{3}{4}$ " x $\frac{1}{4}$ " turn ceramic cartridges (one clockwise closing (left side) and one counter clockwise closing (right side)).

PHL042 – Single $\frac{3}{4}$ " x $\frac{1}{4}$ " turn ceramic cartridge (clockwise closing – left side)

PHL043 – Single $\frac{3}{4}$ " x $\frac{1}{4}$ " turn ceramic cartridge (counter clockwise closing – right side)

PBS019 – Pair of $\frac{3}{4}$ " x $\frac{1}{2}$ " replacement braided hoses.

PSP011 – Two way diverter cartridge with brass splines shaft.

PSH042 – Pair of 15mm non-return valves



CONTRACT ENQUIRIES

+44 (0)1992 708 316

info@lefroybrooks.co.uk

CUSTOMER SERVICE, SPARES & TECHNICAL ENQUIRIES

+44 (0)1902 390 894

technical@lefroybrooks.co.uk

LEFROYBROOKS.CO.UK

Whilst every effort is made to ensure the accuracy of these, they are subject to change without notice as part of the company's product development process. The use of trademarks, product design and artwork is subject to licence or agreement with LBIP Ltd. The design registrations, trademark registrations and copyrights are protected by law and the use or reproduction outside the terms of an agreement is prohibited. The right to modify designs and dimensions is reserved. LBIP Ltd is a member of ACID (Anti Copying in Design). E&OE