

I327 / I328 / I329 / I377 / I381 / I382 / I383 / I384
2140 / 8610 / PPW038 / PPW039 / PPW040

WASTES AND OVERFLOWS
INSTALLATION GUIDE

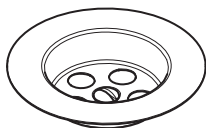
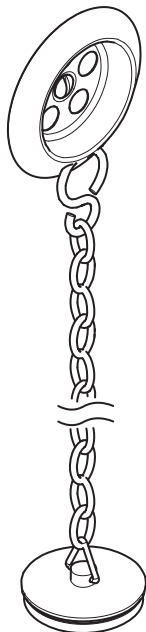

LEFROY BROOKS

IMPORTANT INFORMATION

Professional installation

We recommend that our products are fitted by a fully qualified professional plumber. They should be installed correctly and in accordance with all local water regulations. All products should be accessible for routine servicing.

Water quality

In hard water areas, a suitable water treatment system should be provided to prevent limescale deposits (calcium deposits) which may effect the long term exterior finish. Exterior surfaces should be gently wiped with a dry soft cloth after use to minimise water stains and limescale deposits.

General installation details

Basin wastes have G 1¼" threaded tails and Bath wastes have G 1½" threaded tails.

Mounting holes

Pre-formed holes in chinaware basins and baths are usually made to a standard size to enable the fitting of wastes.

For custom made basins and baths the waste hole sizes should be:

Basin – 44mm to 46mm

Bath – 50mm to 52mm

(For material thickness please refer to the dimensional drawings).

DIMENSIONS

LB 1327 – Basin waste kit with brass plug & oval chain

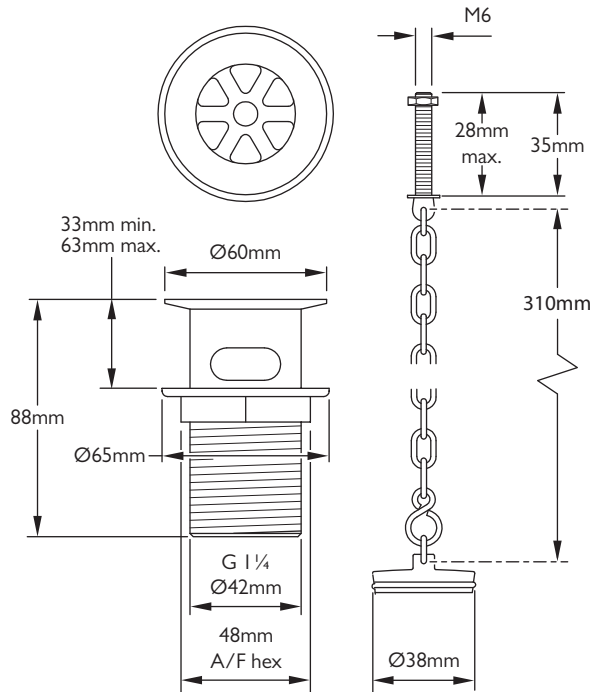

DIMENSIONS

LB 1328 – Slotted click-up basin waste

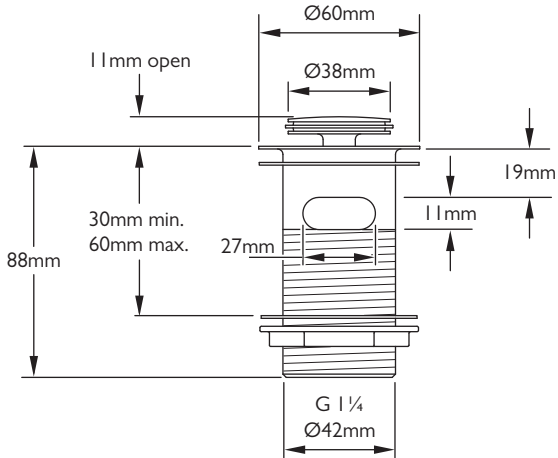

LB 1329 – Un-slotted click-up basin waste

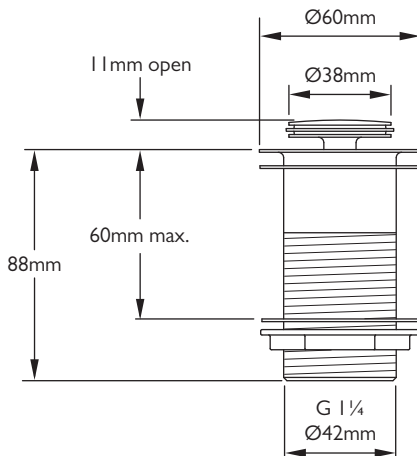

Not to scale

DIMENSIONS

LB I377 – Waste kit with stowaway brass plug & oval chain

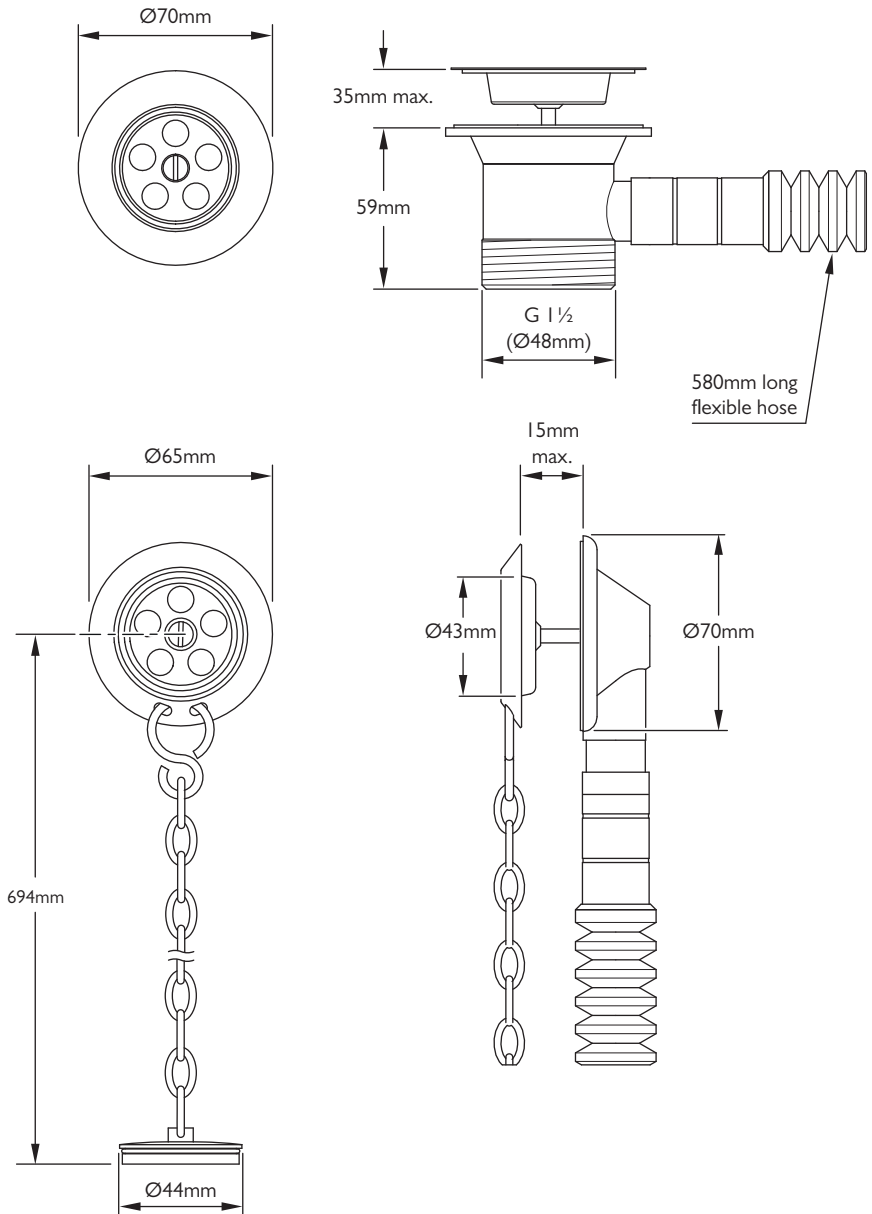

Not to scale

DIMENSIONS

LB 1381 – Easy clean shower waste with removable top

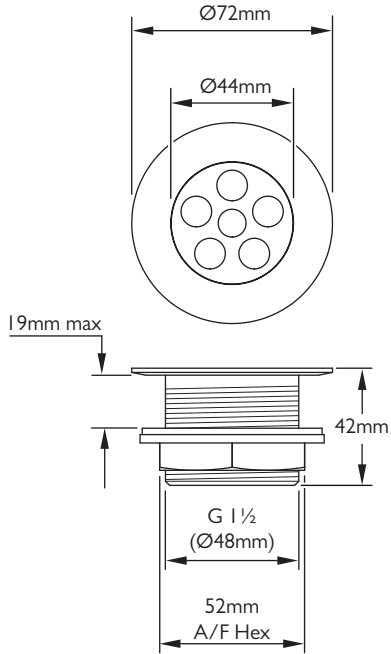

Not to scale

DIMENSIONS

LB 1382 & EXT-LB 1382 – Exposed bath waste with brass overflow pipe for free standing bath

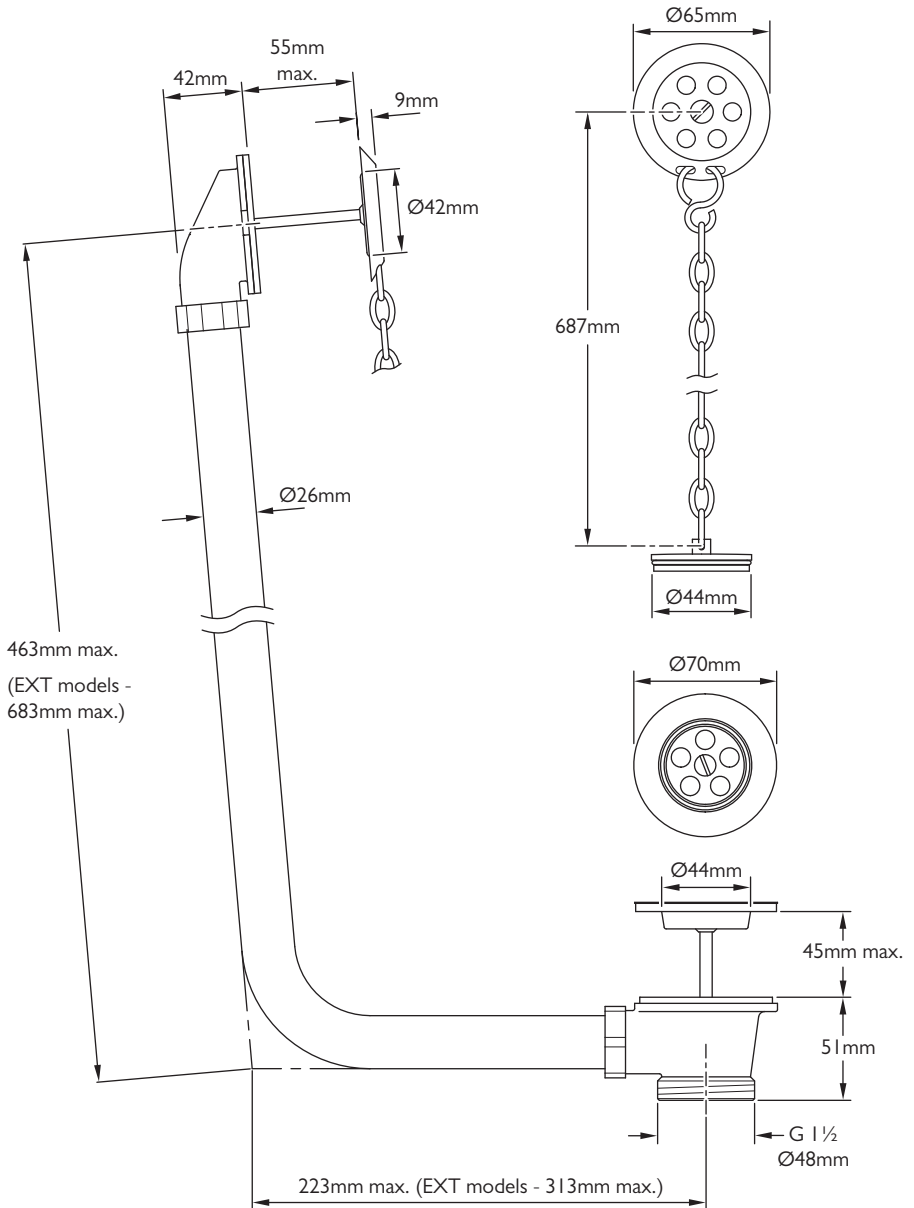

Not to scale

DIMENSIONS

LB 1384 – Belfast sink slotted waste with long chain

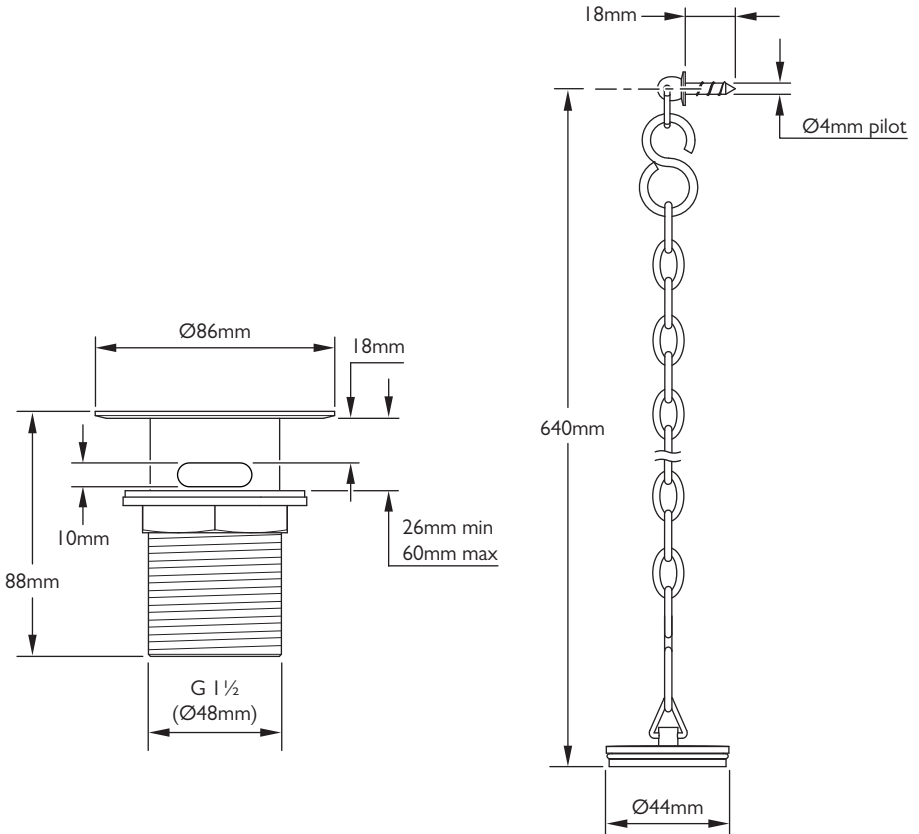

Not to scale

DIMENSIONS

I383 – Pop-up waste kit & assembly

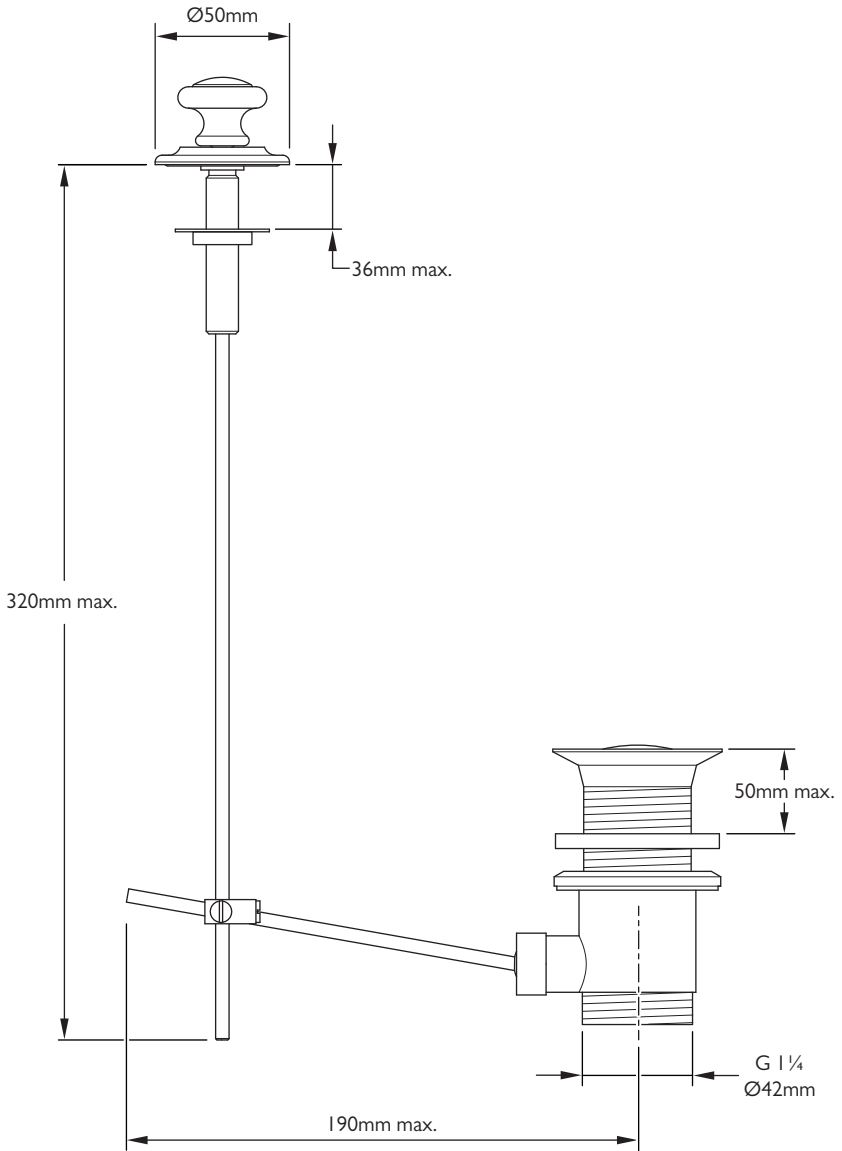

Not to scale

DIMENSIONS

LB 2140 – Basin waste kit with centre hole cover plate

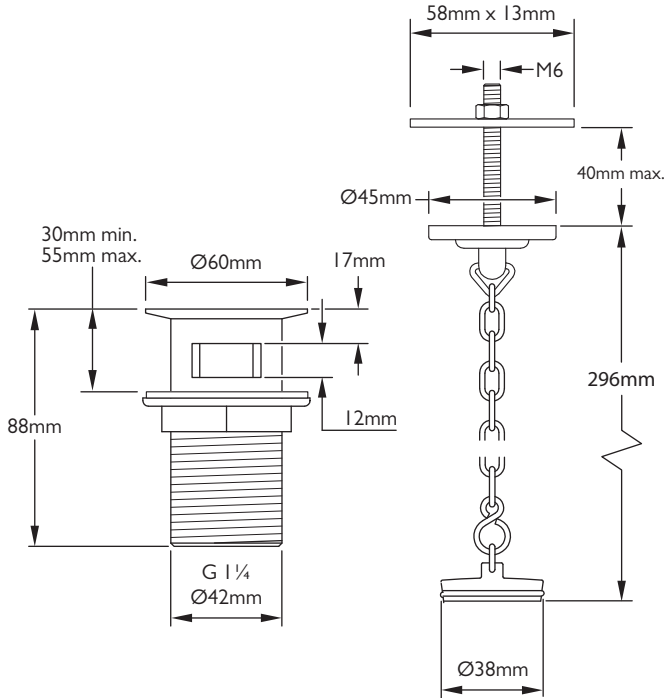

Not to scale

DIMENSIONS

PPW038 – Waste kit with overflow and click-up waste

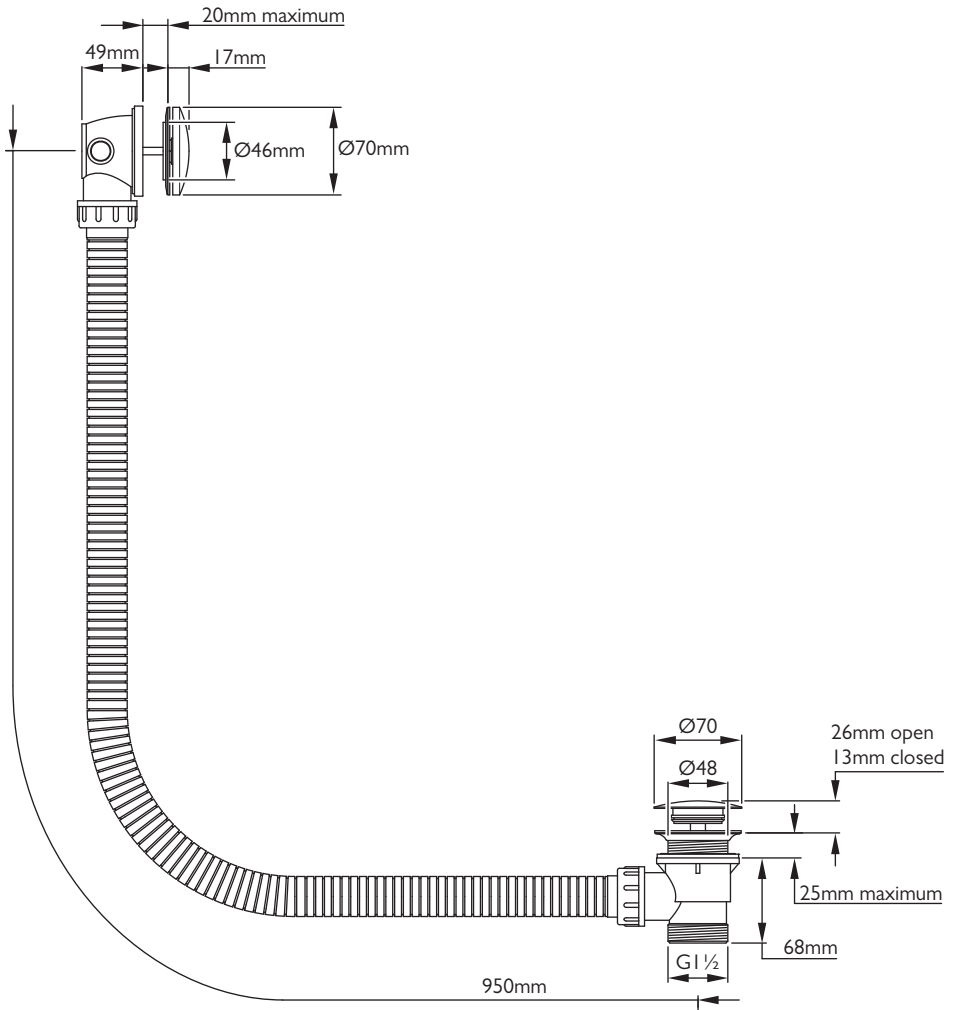

Not to scale

DIMENSIONS

PPW039 – Click-up bath waste

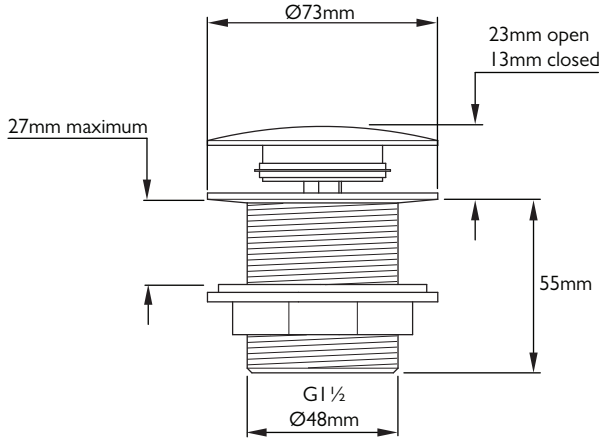

Not to scale

DIMENSIONS

PPW040 – Slow running waste

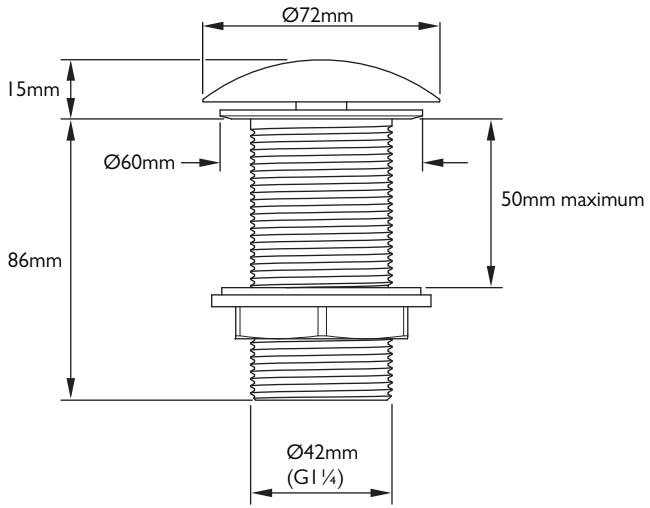

Not to scale

POP-UP WASTE INSTALLATION

1383 – Shown with classic rod. The same procedure applies to all rods

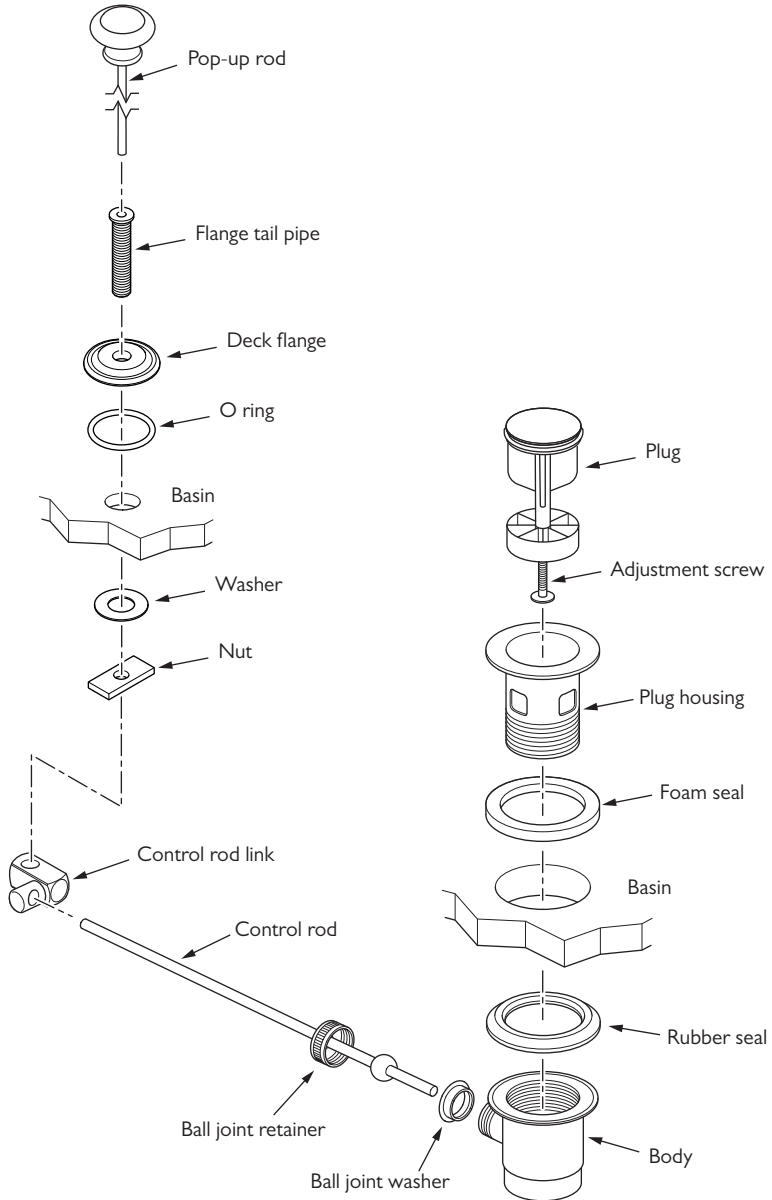

- 1 Locate the deck flange ensuring that the O ring is in place on the underside.
- 2 Pass the flange tail pipe through the deck flange and secure using the washer and nut.
- 3 Insert the pop-up waste lever into the deck flange.
- 4 Assemble the pop-up waste to the basin with the foam seal on top of the mounting surface and the rubber seal below. The wide diameter of the rubber seal sits on top of the waste body. Tighten by hand.
- 5 Place the control rod link onto the rod of the pop-up waste lever, then feed the control rod through. Locate the short end of the control rod, the one with the ball, into the waste and secure by screwing the ball joint retainer in place. Do not over tighten.
- 6 Gently clamp the control rod link to the pop-up waste lever rod. Test the operation of the pop-up waste and if satisfactory fully tighten the control rod link to the pop-up waste lever rod. If not satisfactory then make adjustments to the control rod link as required. If the operation is stiff simply loosen the ball joint retainer as required.
- 7 Connect the flexible hoses to the basin mixer.
- 8 Connect the hot and cold water supplies to the bottom of the appropriate flexible hoses. Turn on the water supplies and check for leaks. Check the operation of the basin mixer.

WASTE INSTALLATION

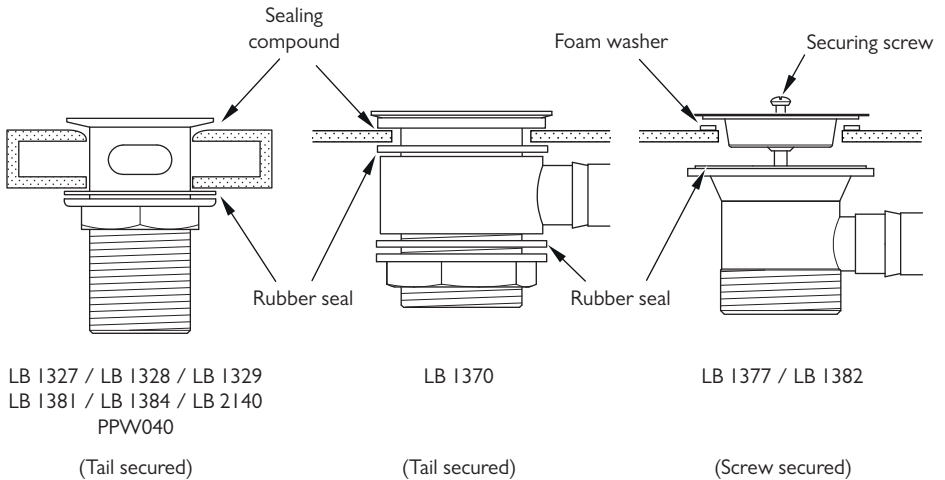

Lefroy Brooks have three waste designs. These are:

- Tail secured wastes that are secured with a nut.
- Tail secured wastes that are secured with a nut and incorporate an overflow connection.
- Screw secured wastes that have a strainer plate secured to the waste by a central slotted screw. These incorporate an overflow connection.

Installation is slightly different for each design.

Tail secured design

- 1 Ensure that the sealing face under basin/bath is flat and clean before fitting the waste.
- 2 Locate the waste into the hole in the basin/bath. To ensure a water tight seal when fitting the waste a foam washer or sealing compound must be used between the waste and the basin/bath.
- 3 On the underside of the basin/bath locate the rubber seal onto the waste.
- 4 On the underside of the basin/bath locate the large nut onto the threaded tail of the waste. Tighten to secure the waste, but do not over tighten.
- 5 Remove any excess sealant or foam washer from inside the basin/bath.

Screw secured design

- 1 Ensure that the sealing face under basin/bath is flat and clean before fitting the waste.
- 2 Locate the strainer plate into the hole in the basin/bath. To ensure a water tight seal when fitting the strainer plate a foam washer or sealing compound must be used between the waste and the basin/bath.
- 3 Locate the rubber seal on top of the waste.
- 4 On the underside of the basin/bath locate the the waste.
- 5 Place the screw through the centre hole in the strainer plate and screw into the waste. Tighten the screw to secure.
- 6 Remove any excess sealant or foam washer from inside the basin/bath.

OVERFLOW INSTALLATION

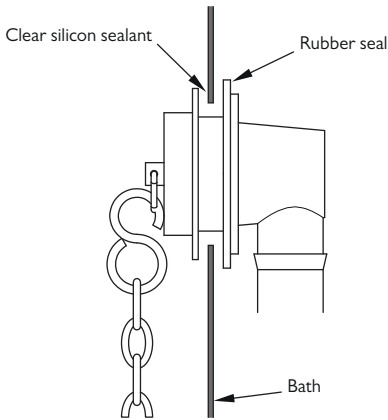

LB 1370
(Tail secured)

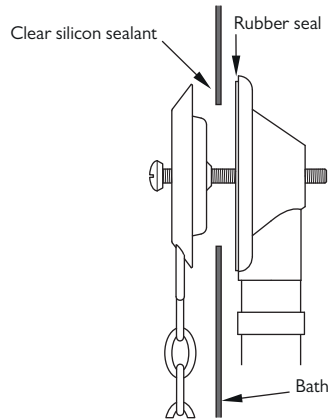

LB 1377 / LB 1382
(Screw secured)

Lefroy Brooks have two designs of overflow. These are:

- Tail secured overflows that are secured with a threaded cover.
- Screw secured overflows that have a cover plate secured to the overflow by a central slotted screw.

Installation is slightly different for each design.

Tail secured design

- 1 Ensure that the sealing face at the front and rear of the bath is flat and clean before fitting the overflow.
- 2 Ensure that the rubber seal is in place then locate the overflow through the hole in the bath. To ensure a water tight seal when fitting the overflow run a bead of clear silicon sealant around the hole in the bath.
- 3 Locate and screw the cover onto the threaded tail of the overflow. Tighten the cover ensuring that the chain retainer is level and the chain hangs vertically.
- 4 Remove any excess sealant from inside the bath.

Screw secured design

- 1 Ensure that the sealing face at the front and rear of the bath is flat and clean before fitting the overflow.
- 2 Ensure that the rubber seal is in place then locate the overflow to the rear of the hole in the bath.
- 3 To ensure a water tight seal when fitting the cover plate run a bead of clear silicon sealant around the hole in the bath.
- 4 Locate the cover plate and screw.
- 5 Tighten the screw to secure the cover plate ensuring that the chain retainer is level and the chain hangs vertically.
- 6 Remove any excess sealant from inside the bath.

FLEXIBLE OVERFLOW HOSE INSTALLATION

Under normal circumstances there is no requirement for sealant to be used on the joints of the overflow flexible hose. Water only flows through the flexible hose when the basin/bath overflows. When water does flow through the hose it is free flowing and not pressurised. Sealant can however be used if you prefer.

The overflow hose is designed to be pushed onto the overflow connections and be self supporting.

LB 8610 GRATED OVERFLOW COVER INSTALLATION

The grated overflow cover is designed for use with LB 1377 & LB 1382 bath wastes only.

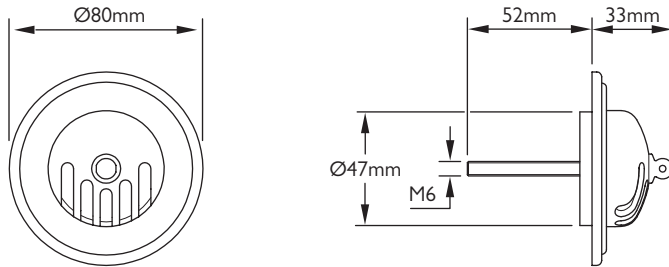

Replacing an existing overflow

- 1 Remove the centre screw from the existing overflow.
- 2 Remove the overflow cover plate from the existing overflow.
- 3 Carefully remove any silicon sealant.
- 4 To ensure a water tight seal when fitting the grated overflow run a bead of clear silicon sealant around the hole in the bath.
- 5 Locate the grated overflow and screw.
- 6 Place a 2.5mm diameter rod or small screwdriver through the hole in the end of the screw to tighten and secure the grated overflow.
- 7 Remove any excess sealant from inside the bath.



CONTRACT ENQUIRIES

+44 (0)1992 708 316

info@lefroybrooks.co.uk

CUSTOMER SERVICE, SPARES & TECHNICAL ENQUIRIES

+44 (0)1902 390 894

technical@lefroybrooks.co.uk

LEFROYBROOKS.CO.UK

Whilst every effort is made to ensure the accuracy of these, they are subject to change without notice as part of the company's product development process. The use of trademarks, product design and artwork is subject to licence or agreement with LBIP Ltd. The design registrations, trademark registrations and copyrights are protected by law and the use or reproduction outside the terms of an agreement is prohibited. The right to modify designs and dimensions is reserved. LBIP Ltd is a member of ACID (Anti Copying in Design). E&OE